

WHAT'S DAT?

Identifying & Prioritizing Magnetic Media

NEA Spring Meeting - April 1, 2016
Jessica Bitely, NEDCC
Rebecca Chandler, AVPreserve

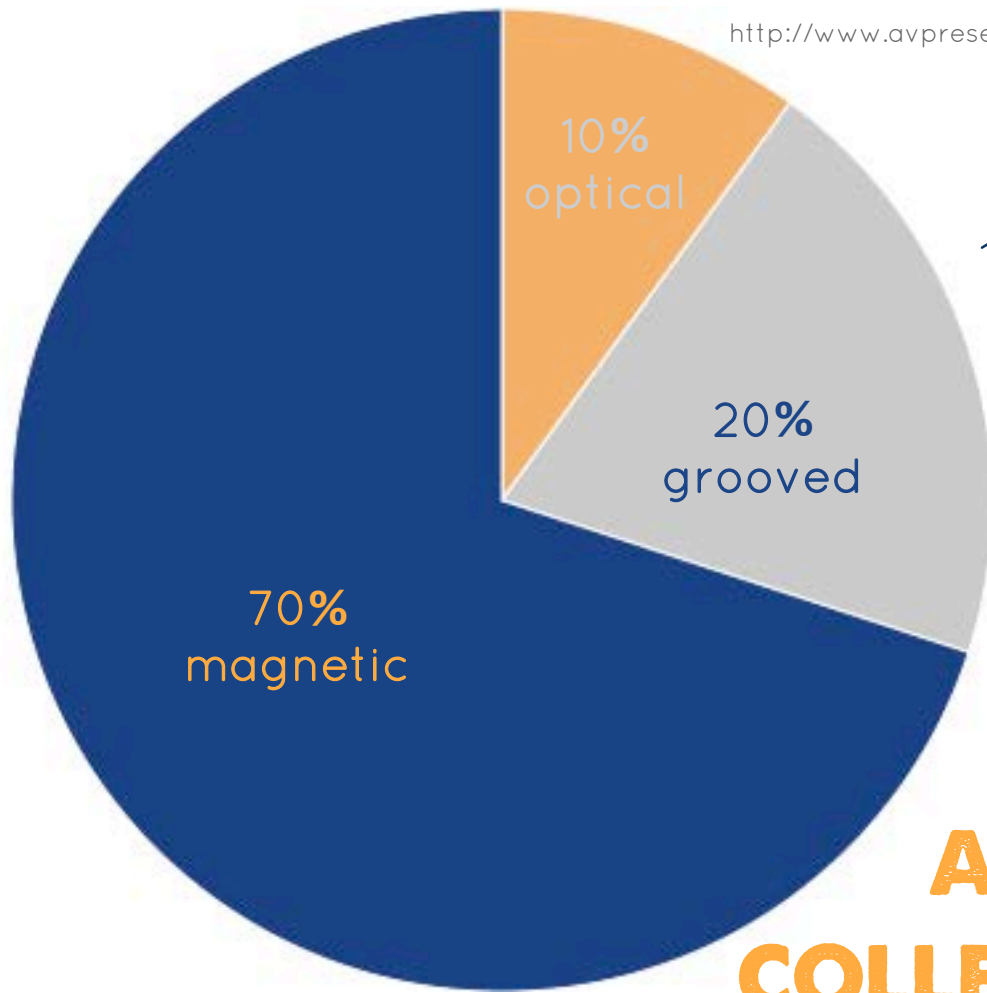

178 million preservation-worthy magnetic audio assets

AUDIO FORMATS IN COLLECTIONS IN THE US



2028

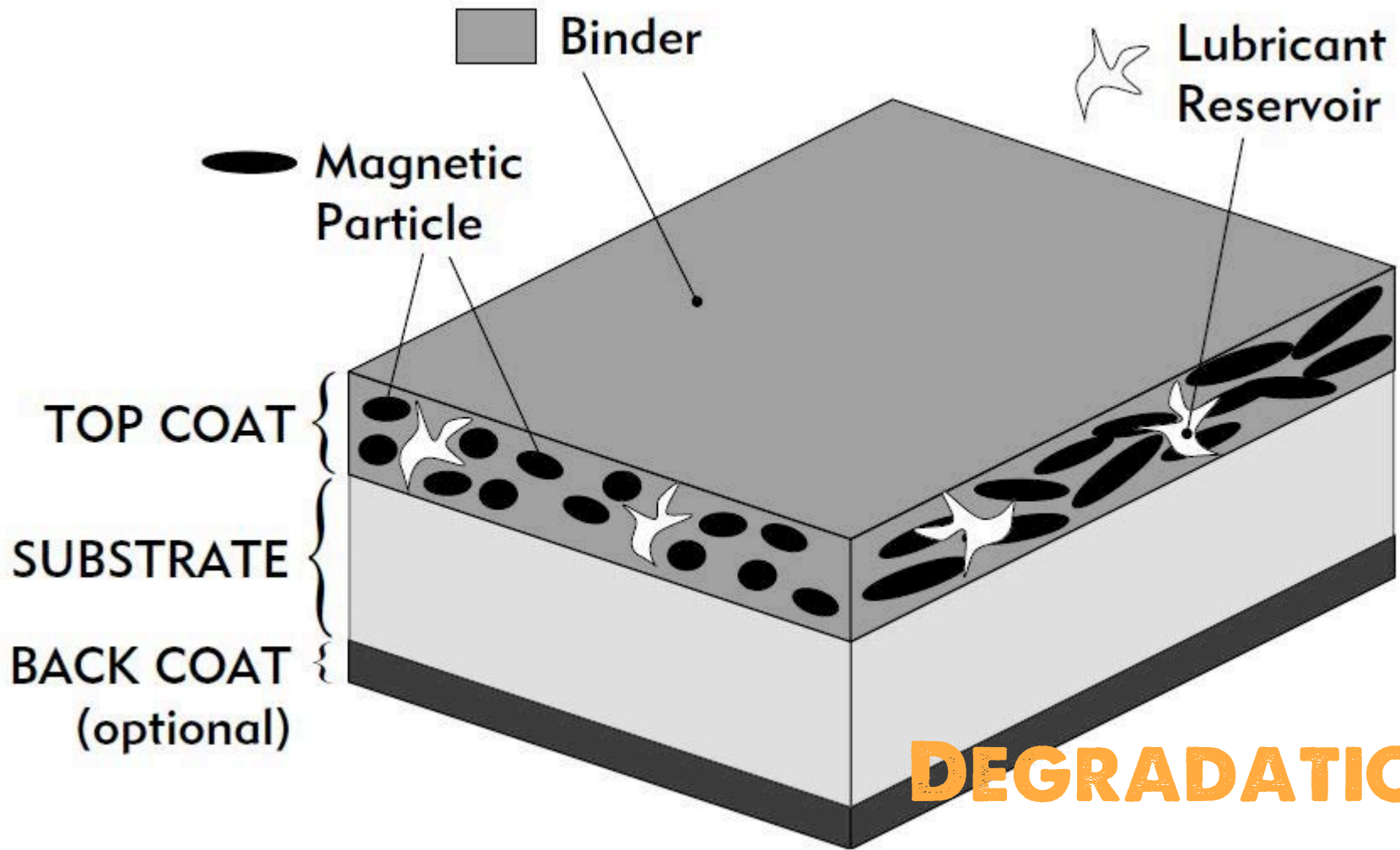

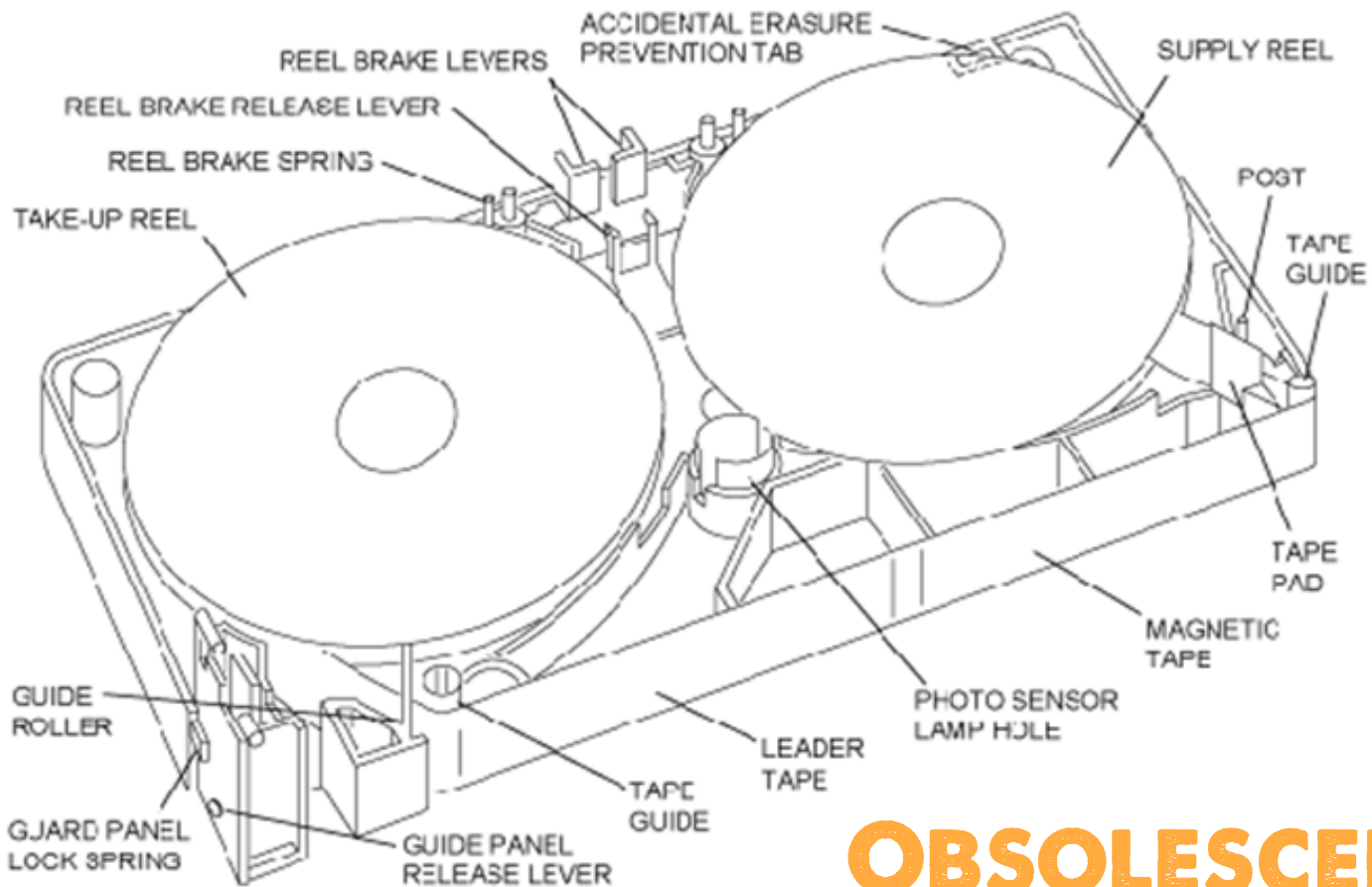

OBSOLESCENCE

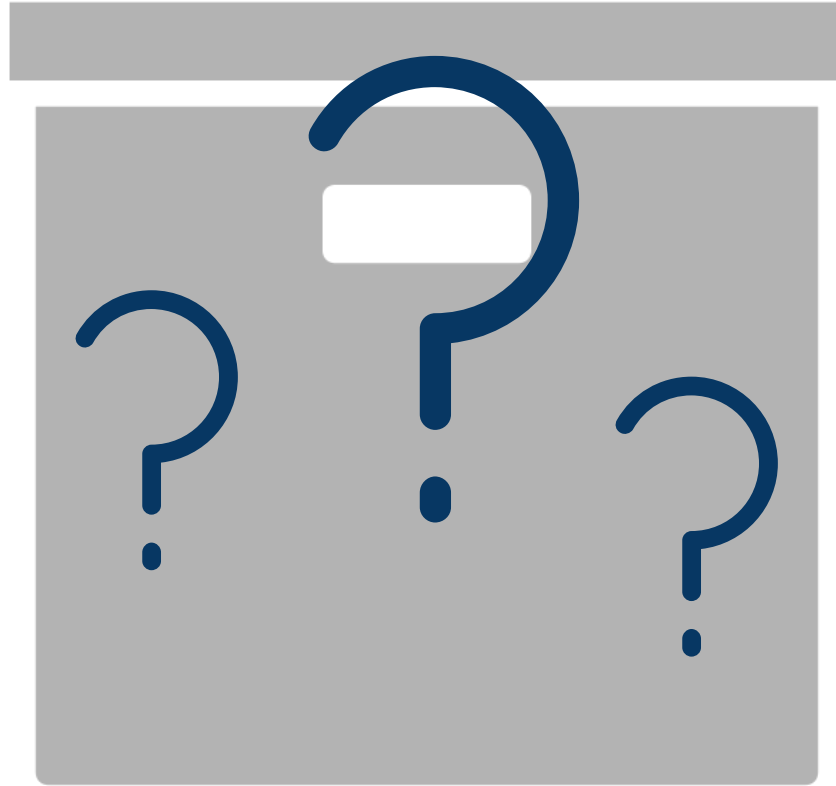

**LACK OF
INTELLECTUAL CONTROL**

PRIORITIZE!

1

2

3

Mission

Advocacy

Access

Planning & Budgeting

Goals

Reformatting

Fundraising

Collections Management

Outreach

Needs

Short term

What resources do you have to devote to processing/reformatting? How robust is the format? How accessible are playback devices? How important is the collection/item?

Long term

How will the information (metadata!) you capture now help you in the future? Do you have the resources to steward materials over time?

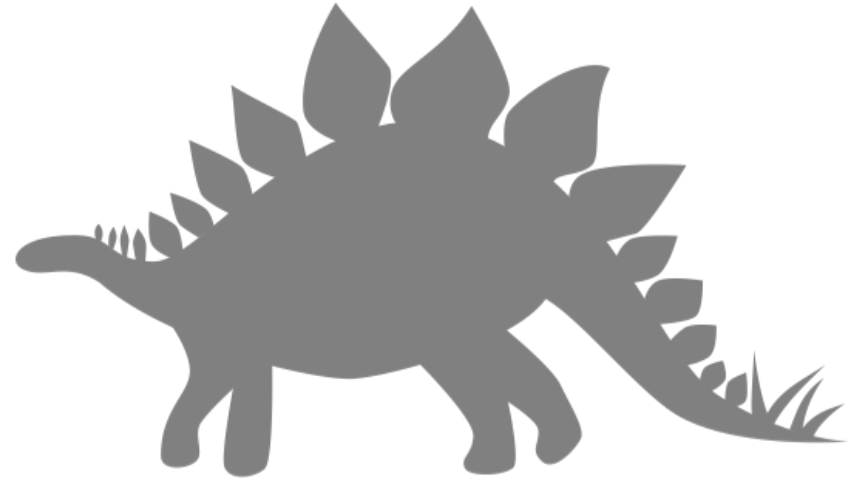

TECHNICAL NEEDS



CONTENT VALUE

Mission Statement

Describes the institution's goals and objectives, its users, and how the collection supports them

Collecting Policy

Provides guidelines for acquisition, deaccession, and preservation planning, including format specific considerations.

USE VALUE

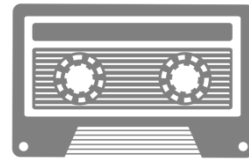
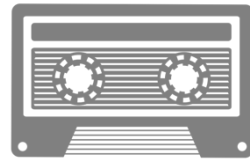
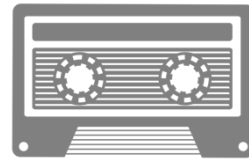
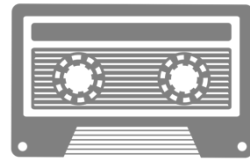
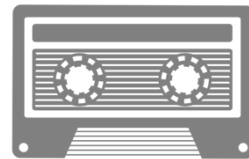
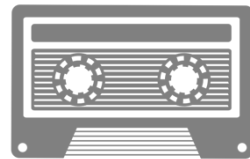
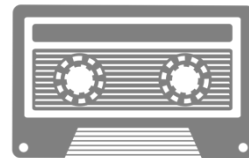
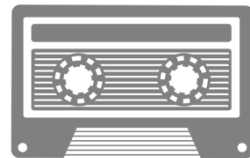
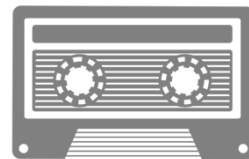
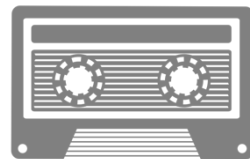
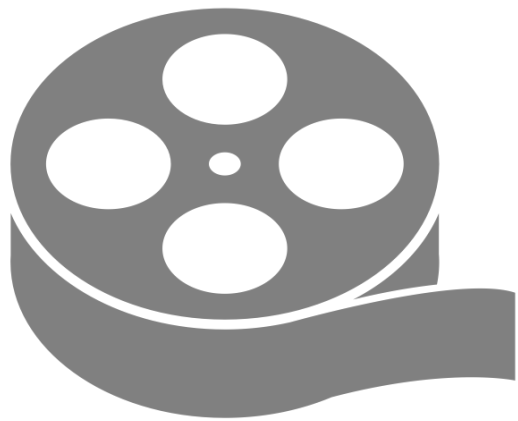

COST TO DIGITIZE





INDIANA UNIVERSITY

MEDIASCORE



= format commonly found in archives

BETA VARIANTS



BETACAM SP™

5.69"

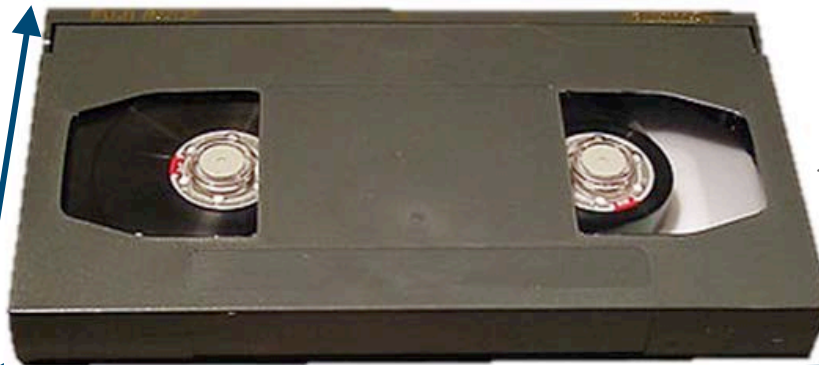

1982

9.31"

3.75"



6.13"



VHS

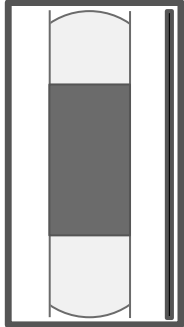

1976



DV VARIANTS



DVCPRO

Mini **DV**

DVCAM

3"



4.88"

1.88"



2.56"

1995



BETAMAX

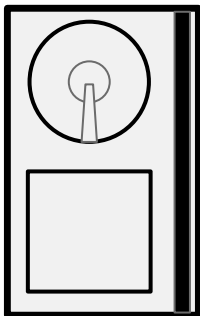

3.75"



6.13"

1975



VIDEO8 & Hi8

Hi8

Video8

2.38"

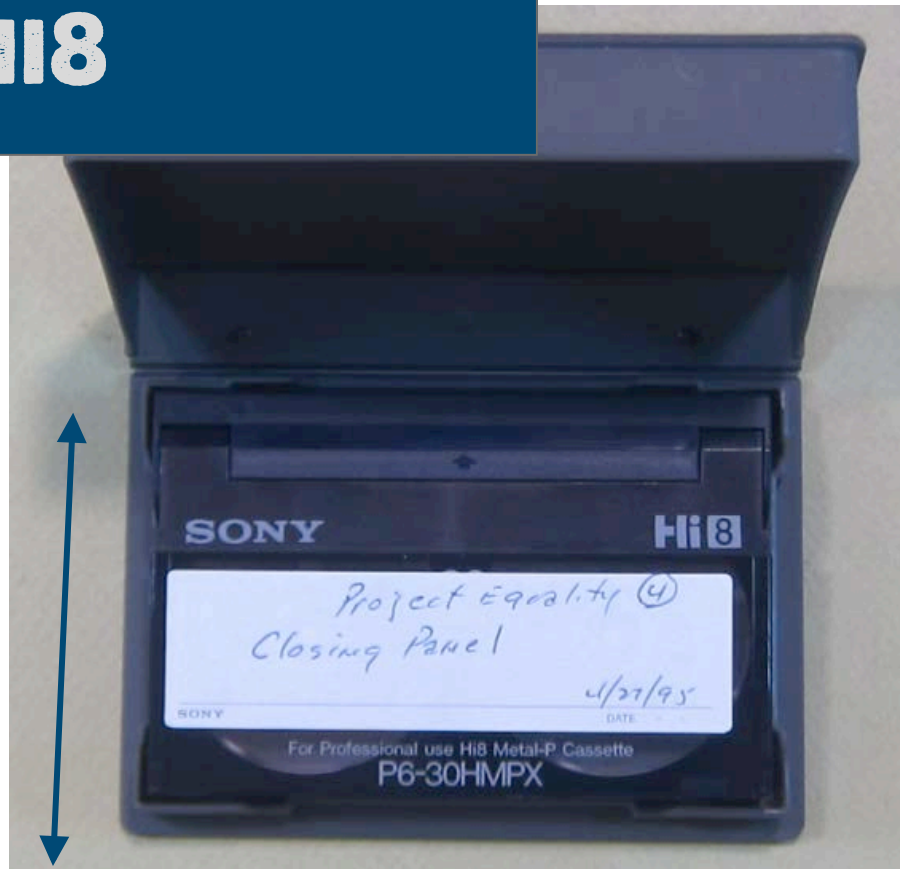

3.69"

1984



U-MATIC



1971

8.63"
or
7.25"

5.38" or 4.63"



D1, D2, D3, D5

6.75"
up to
10"



4.25" up to 5.88"

1980s



OPEN REEL VIDEOTAPE

1/2", 1", 2" (quad)

1956



Image by Flickr user DRs Kulturarvsprojekt

AUDIO



COMPACT CASSETTE, AKA AUDIOCASSETTE



1964

MICRO CASSETTE

2.4"



1.3"

2.2"

1.5"

1969

MINI CASSETTE

8-TRACK CARTRIDGE



1963



4"

5.25"

DTRS, AKA DA-88

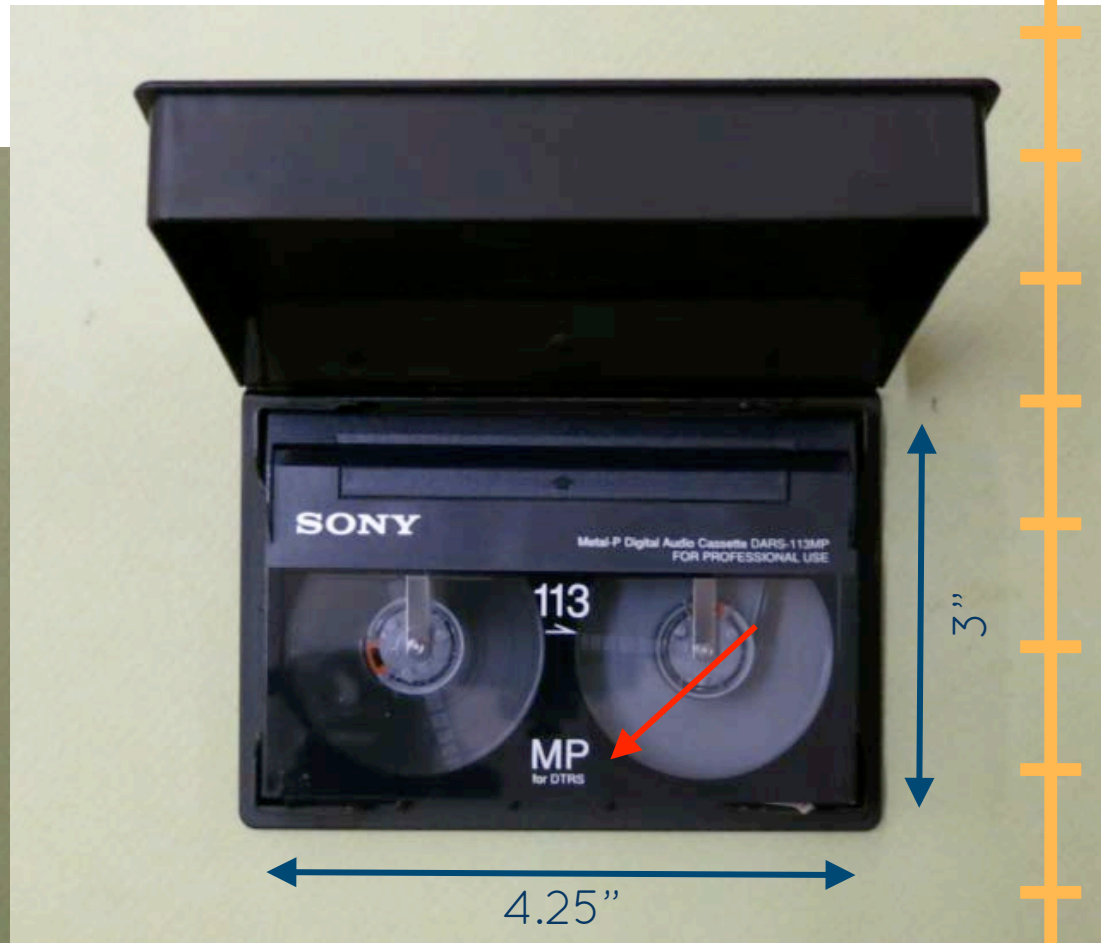
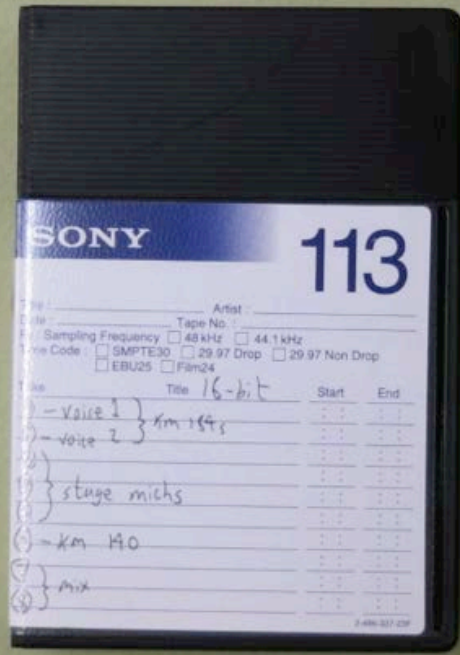

OPEN REEL AUDIO TAPE



late 1940s

1. PVC
2. polyester
3. paper
4. acetate



OPEN REEL AUDIO TAPE

PVC and polyester



OPEN REEL AUDIO TAPE

paper



OPEN REEL AUDIO TAPE

acetate



OPEN REEL AUDIO TAPE

1/4", 1/2", 1", 2"

MASTER REEL CONTROL FILE

PROJECT NO. _____
PRODUCER/CLIENT: Time Life
ARTIST: Casablanca Session No. _____ Reel No. _____

TAPE NO.	TITLE OR DESCRIPTION	TAKES AND TIMES
	<u>SWEDISH TAPA - R I - A - 20</u>	
	<u>THOMAS</u>	
	<u>BUGLE CALL BANG</u>	
	<u>THIS GUY'S IN LOVE</u>	
	<u>STEALING APPLES</u>	
	<u>VIVA LADIES</u>	
	<u>SATIN DOLL</u>	
	<u>WILLIAM WALKER FOR ME</u>	
	<u>DUB OF 4 TR. OC12</u>	
	<u>ON TA TAKES 3, 4, 5, 6</u>	
	<u>DOLBY</u>	

LIBRARY FILMS INSTRUCTIONS

THIS TAPE IS: MONO 2-TRACK 3-TRACK 4-TRACK 80

RECORDED ON MACHINE # _____ STUDIO WET DRY

FILE CATEGORY: CAS CAPITOL MOTION SINGLES HOLD ALBUM PROJ. FILE

ENGINEER _____ DATE: 3/5/72

Capitol
MAGNETIC TAPE



AUDIO ON VIDEOCASSETTE

U-matic 1600/1610/1630

PCM-F1 = betamax

ADAT = VHS

U-matic 1600-early
1980s

PCM-F1-1982

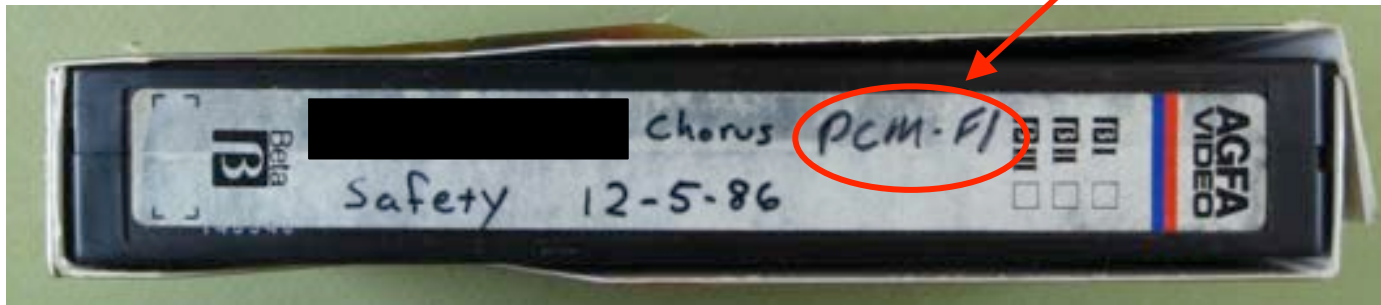

ADAT-1991

WIRE RECORDING



1939



DIGITAL AUDIO TAPE, AKA DAT



2.13"



2.87"

1987



FORMAT EQUALIZERS

LONG PLAY



mold



funny
smells



unidentified
goo



flakes

long play tapes



unspooled
tape/broken
carrier

WORK IT.

Each table is a team

Each team has one prompt and one set of “tapes”

Choose one team member to report findings

Be ready at 2:30 to discuss!!!

RESOURCES

California Audiovisual Preservation Project - Audiovisual Formats, A Guide to Identification

http://calpreservation.org/wp-content/uploads/2013/10/2013-Audiovisual-Formats_draft_webversion-2013oct15.pdf

Preservation Self-Assessment Guide - Format ID Guide

<https://psap.library.illinois.edu/format-id-guide>

Texas Commission on the Arts - Videotape Identification and Assessment Guide

<http://www.arts.texas.gov/wp-content/uploads/2012/04/video.pdf>

Mike Casey, Why Media Preservation Can't Wait: the Gathering Storm

http://www.avpreserve.com/wp-content/uploads/2015/04/casey_iasa_journal_44_part3.pdf

MediaSCORE & MediaRIVERS

<https://www.avpreserve.com/tools/mediascore-mediarivers/>

FACET Format Characteristics and Preservation Problems

http://www.dlib.indiana.edu/projects/sounddirections/facet/facet_formats.pdf

National Endowment for the Humanities - Preservation Assistance Grants

<http://www.neh.gov/grants/preservation/preservation-assistance-grants-smaller-institutions>

THANK YOU!



jbitely@nedcc.org



rebecca@avpreserve.com

IN THIS PRESENTATION

ICONS FROM:

Noun Project: Andrew Forrester, Evert Jan Boon, Ryan Speziale, Vanessa Choi, Samu Parra, Alex Tai, Mister Pixel, Joe Mortell, Jon Testa, Herbert Spencer, Sandra M, Charlotte Vogel, vanilla, Marie Van den Broeck, Alfredo Hernandez, Zane Ogle, YEJIN